

## Ethernet Controller Design

2010-01-31 20:01:57 by Nick

An Ethernet controller (also known as a Network Interface or NIC) is another component that every THAT module will need to contain for THAT-conformance. Although not required, it is likely that most THAT modules will make use of identical or very similar NIC designs.

With this in mind, I began the design process for a NIC “sub-module” for use with my Digital Thermostat Module. The main purpose of the NIC is to use an Ethernet controller IC to implement all low-level network functions in hardware. Additionally, the NIC contains the physical connection port and all the magnetics (transformers and chokes) to complete the IEEE 802.3-compliant network interface.

Since the Ethernet controller IC is the main component of the NIC, I selected it first. Unfortunately, there are almost no Ethernet controllers made in through-hole IC packages. Designing around through-hole components is important to me for many reasons; the most important being that surface-mount packages are very difficult to solder or de-solder without either expensive tools or a lot of experience.

One decent Ethernet controller that IS available in a through-hole package is the Microchip ENC28J60 Ethernet Controller [Datashheet]. The main benefits of the ENC28J60 are that it uses a standard 3-wire serial (SPI) interface for communication with a microcontroller, has only 28-pins, supports auto-negotiation and half or full duplex, and is relatively low-priced. A typical application schematic for the ENC28J60 is shown below.

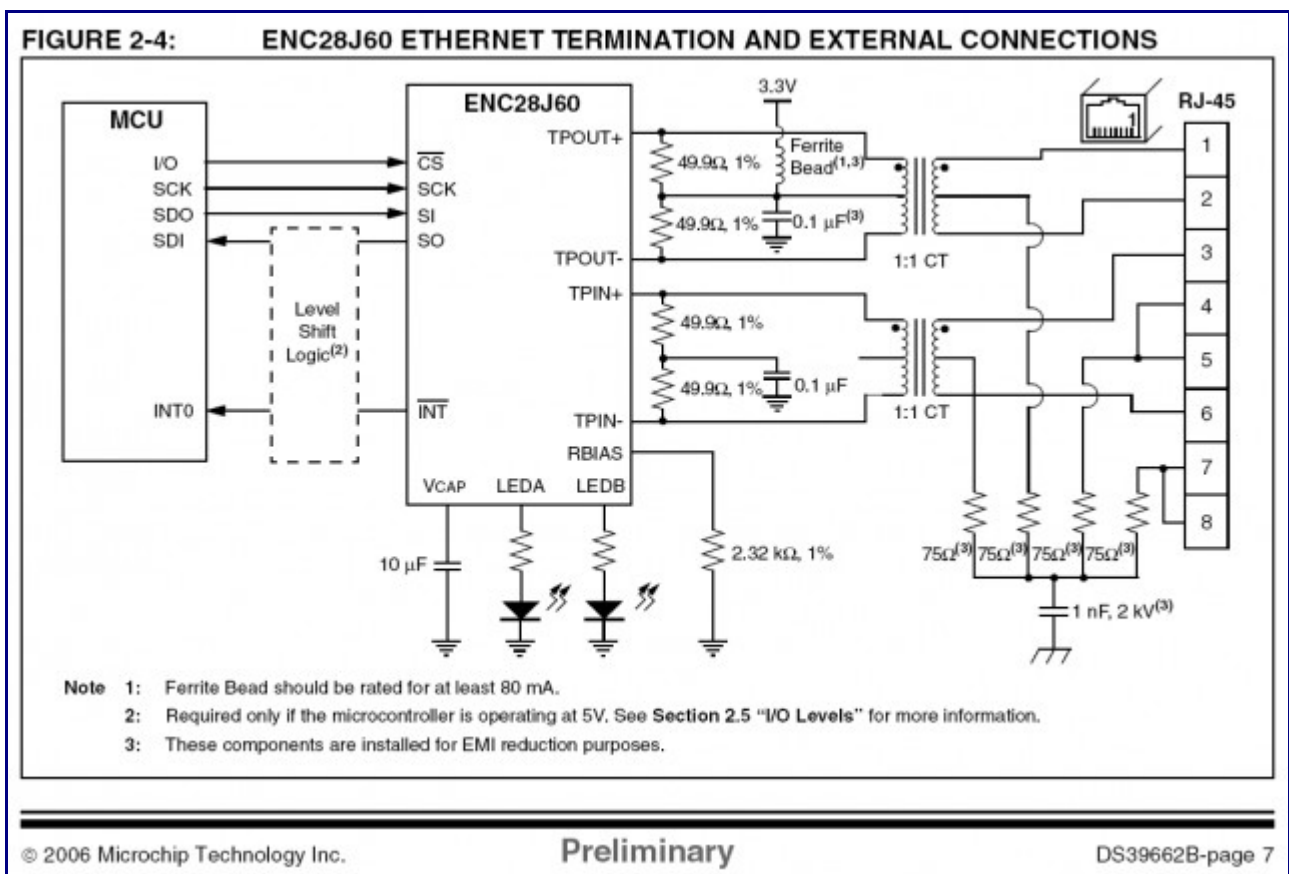

Using the application examples from both Microchip’s ENC28J60 Datasheet as well as Guido Socher’s documentation of his AVR microcontroller based Ethernet Device, I have completed the preliminary schematic and parts list for my NIC sub-module. My schematic and parts lists are included below.

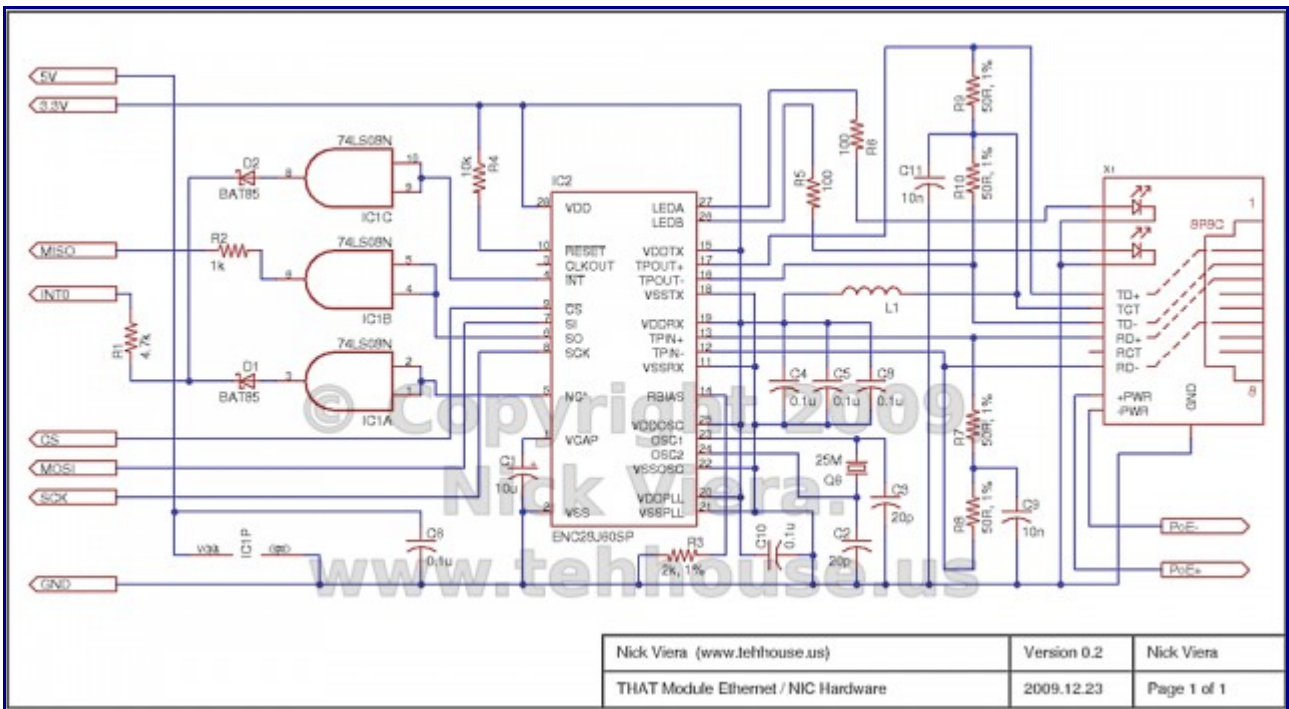

Nick Viera (www.tehhouse.us)	Version 0.2	Nick Viera
THAT Module Ethernet / NIC Hardware	2009.12.23	Page 1 of 1

Parts List														
Part ID	Type	Attr.	Temperature		Package	Digikey Part	Manufacturer Part	Unit Price			Extended Price			
			Min.	Max.				x1	x25	x100	Qty	x1	x25	x100
C1, C2	Capacitor	10uF, 25V, electro.	-40	85	Round, 4mm	P813-ND	ECE-A1EKA100	0.14	0.09	0.06	2	0.28	0.18	0.12
R1,2	Resistor	1k, 5%, carbon	-55	155	Axial	CF141KJRCT-ND	CF 1/4 1K 5% R	0.08	0.05	0.02	2	0.16	0.11	0.04
R4	Resistor	10k, 5%, carbon	-55	155	Axial	CF1410KJRCT-ND	CF 1/4 10K 5% R	0.08	0.05	0.02	1	0.08	0.05	0.02
R5,6	Resistor	100, 5%, carbon	-55	155	Axial	CF14100JRCT-ND	CF 1/4 100 5% R	0.08	0.05	0.02	2	0.16	0.11	0.04
R3	Resistor	2k, 1%, film			Axial	RNF1/4T12KFRCT-ND	RNF 1/4 T1 2K 1% R	0.15	0.11	0.04	1	0.15	0.11	0.04
R7-10	Resistor	50, 5%, carbon	-55	155	Axial	51QBK-ND	CFR-25JB-51R	0.08	0.05	0.02	4	0.32	0.21	0.09
C3,4	Capacitor	20pF, 50V, ceramic	-55	125	2.54mm grid	490-3703-ND	RPE5C1H200J2P1Z03B	0.32	0.24	0.17	2	0.64	0.48	0.34
C5-9	Capacitor	0.1u, 50v, ceramic	-55	125	2.54mm grid	BC1084CT-ND	K104K15X7RF5TL2	0.08	0.08	0.06	5	0.41	0.41	0.29
IC2	IC	Ethernet controller, SPI	-40	85	DIP-28	ENC28J60-I/SP-ND	ENC28J60-I/SP	3.86	2.77	2.51	1	3.86	2.77	2.51
IC1	IC	Quad AND gate	-40	125	DIP-14	568-1505-5-ND	74HCT08N.652	0.42	0.34	0.23	1	0.42	0.34	0.23
C10,11	Capacitor	10nF, 50v, ceramic	-55	125	2.54mm grid	BC1078CT-ND	K103K15X7RF5TL2	0.07	0.07	0.05	2	0.14	0.14	0.10
Q6	Crystal	25MHz, 20pF, +/-50ppm	-20	70	HC49/US	631-1112-ND	FOX5LF/250F-20	0.53	0.45	0.30	1	0.53	0.45	0.30
D1,2	Diode	Schottky, 200mA, 30V	-65	125	DO34/35	568-1617-1-ND	BAT85	0.30	0.23	0.16	2	0.60	0.45	0.31
X1	Connector	8P8C, Mag, PoE, 2-LED			Rectangle	A99644-ND	1-6605310-1	7.90	6.79	5.37	1	7.90	6.79	5.37
Parts List - Ethernet Interface 0.3 - Nick Viera - 2009.12.28								<b>Total:</b>			<b>27</b>	<b>15.64</b>	<b>12.59</b>	<b>9.82</b>

Notes:

- The modular jack I've selected (Digikey P/N A99644-ND) contains the necessary additional components for proper IEEE 802.3 support. These include two 1:1 center-tapped transformers, matched chokes, and bridge rectifiers needed to capture PoE power. The jack also includes two LEDs which will be used to indicate network link and activity.
- The AND Gate (IC1) is being used as a buffer to convert the ENC28J60's 3.3 Volt outputs to 5 Volt logic. If the microcontroller is operated at 3.3 Volts, this IC can be omitted.
- The ENC28J60 uses a 25 MHz crystal to drive its internal oscillator. It can then output a clock signal of various speeds using an internal divider / prescaler. I may feed this clock output into the microcontroller's XTAL1 pin to provide it with a clock in a future revision (depending on final voltage and speed requirements)
- 50-ohm, 1% tolerance resistors are (apparently) difficult to find. Substitutions of 49.9, 51, or similar resistances worked during initial testing.
- The choke L1 is ill-defined. The ENC28J60 datasheet only suggests that the choke must be rated to carry at least 80mA. Guido Socher from tuxgraphics.org reports that a handful of turns around a 5mm ferrite bead works well.